



UNIVERSAL SILENCER

A DIVISION OF NELSON INDUSTRIES, INC.

We're Leading A Quiet Revolution®

Absorptive Silencers

Product Catalog No. 245-B

General Information

Absorptive Silencers

The Absorptive type silencer is the classic dissipative design, deriving its noise control properties from the basic fact that noise energy is effectively "absorbed" by various types of fibrous packing materials. More technically, as the sound waves pass through the spaces between the tightly-packed small-diameter fibers of the absorptive material, the resulting viscous friction dissipates the sound energy as small amounts of heat.

Absorptive silencers are highly effective on high frequency noise (500 - 8000 Hz). At frequencies above and below this range, attenuation performance progressively diminishes.

Since the noise is absorbed by the packing media, the absorptive silencer does not rely on internal baffles, tubes, or other restrictive devices to achieve noise reduction. Consequently, absorptive silencers generally employ straight-through or similar internal designs which impose very little restriction to the air flow.

U5 Series (page 3) Highly efficient straight-through silencer available in pipe sizes 1/2" - 6". Attenuation characteristics equivalent to SU5 series.

U2 Series (page 4) Moderately efficient straight-through silencer available in pipe sizes 5" - 30". For higher performance, use SU3, SU4, SU5, or U5 series.

SU5 Series (page 5) Highest efficiency full flow annular type silencer. Available in pipe sizes 4" - 60". Larger sizes on application.

SU4 Series (page 6) Annular type silencer with performance one grade lower than SU5 series. Available in pipe sizes 8" - 60". Larger sizes on request.

SU3 Series (page 7) Annular type silencer with performance two grades lower than SU5 series, available in pipe sizes 8" - 60" and larger. For higher attenuation, use SU4 or SU5 series.

Sizing Information, Pressure Drop Data

The flow area through the silencer must be sufficient to accommodate the maximum flow without imposing excessive pressure drop. The following instructions enable the user to 1) select proper silencer size, and 2) determine actual pressure drop. (These instructions assume air as the flowing gas. For other gases, density and other corrections may be necessary - contact Universal for assistance.)

Data Required:

- Air flow rate (Actual CFM)
- Temperature (°F)
- Pressure (psig)
- Maximum pressure drop (inches of water)

1. Determine Maximum Velocity:

$$V = 4005 \sqrt{\left(\frac{\Delta P}{c}\right) \left(\frac{14.7}{P + 14.7}\right) \left(\frac{T + 460}{530}\right)}$$

- V = Air or gas velocity, ft/min (see Note 1)
- ΔP = Maximum pressure drop, inches of water
- c = Silencer pressure drop coefficient (Table 1)
- T = Air temperature, °F (See Note 2)
- P = Operating pressure, psig (If at atmospheric pressure, pressure ratio is unity and may be omitted from equation. If P exceeds 15 psig, contact Universal for recommendations.)

2. Determine flow area required:

$$A = \frac{Q}{V}$$

- A = Flow area required, ft²
- Q = Air flow rate (Actual CFM)

$$\text{Actual CFM} = \text{Standard CFM} \left(\frac{14.7}{P + 14.7}\right) \left(\frac{T + 460}{530}\right)$$

3. From Table 2, select size with flow area equal to or greater than that calculated.

4. Determine actual gas velocity, ft/min

$$V_{\text{actual}} = \frac{Q}{A}$$

A = Flow area from Table 2.

5. Determine actual pressure drop:

$$\Delta P = c \left(\frac{V_{\text{actual}}}{4005}\right)^2 \left(\frac{530}{T + 460}\right) \left(\frac{P + 14.7}{14.7}\right)$$

Table 1. Pressure Drop Coefficients

SILENCER SERIES	PRESSURE DROP COEFFICIENT-c
U5, U2	.25
SU5	.75
SU3, SU4	.85

Table 2. Flow Area Size

Flow Area-ft ²	Dia. (Size)-in.	Flow Area-ft ²	Dia. (Size)-in.
.0014	1/2	2.6	22
.0031	3/4	3.1	24
.0055	1	3.7	26
.012	1 1/2	4.3	28
.022	2	4.9	30
.034	2 1/2	5.6	32
.049	3	6.3	34
.067	3 1/2	7.1	36
.087	4	7.9	38
.136	5	8.7	40
.196	6	9.6	42
.349	8	10.6	44
.55	10	11.5	46
.79	12	12.6	48
1.07	14	15.9	54
1.4	16	19.6	60
1.8	18	23.8	66
2.2	20	28.3	72

NOTES:

1. Since self noise and aerodynamic noise generation increase with velocity, absorptive silencers are usually sized for 4,000 - 8,000 ft/min. In no case should the velocity exceed 15,000 ft/min, regardless of pressure drop allowed.
2. Typical attenuation curves are given to indicate the characteristics of the silencer series and, as such, are neither a minimum nor a guarantee for an individual silencer. Individual silencer performance can be affected by many other environmental and operational factors, such as the sound source characteristics including pure tones, flow velocity, adjacent piping and temperature.

Specifications U5 Series

Straight-Through
Silencer

NOTE: U5 Series Standard Paint and Acoustical Packing are suitable for 325°F.

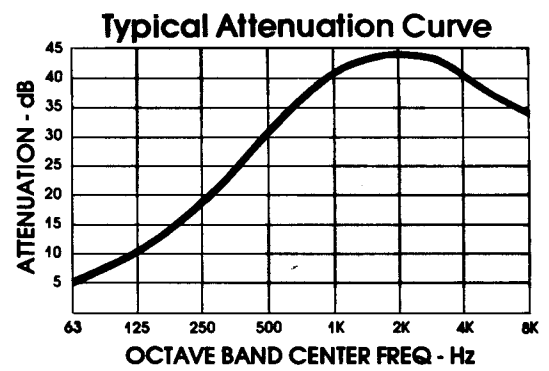

The U5 series is a premium, straight-through, absorptive silencer. It provides excellent noise attenuation due to its very high length to diameter ratio. It is especially well suited for inlet service on small rotary positive or centrifugal blowers or the discharge of vacuum pumps. Mild steel construction with enamel paint.

Common Applications:

- Blower inlet
- Vacuum Pump discharge
- Air Valves and cylinders
- Small low pressure vents
- Any high frequency noise source

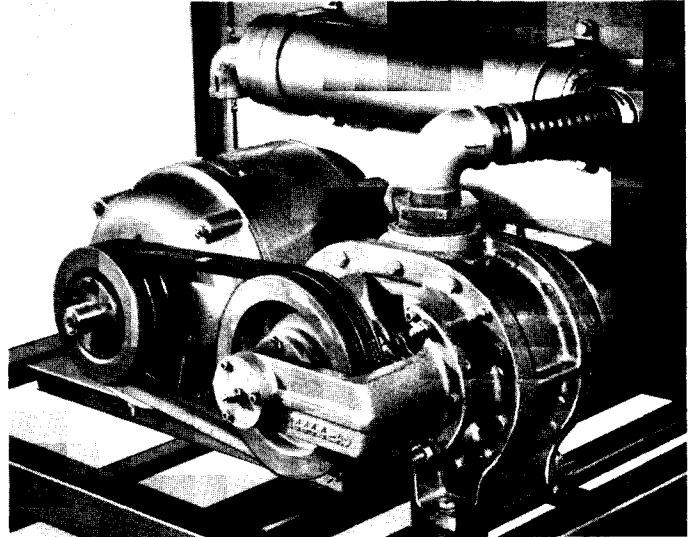

Typical Installation shows U5 silencer on inlet of small rotary positive blower.

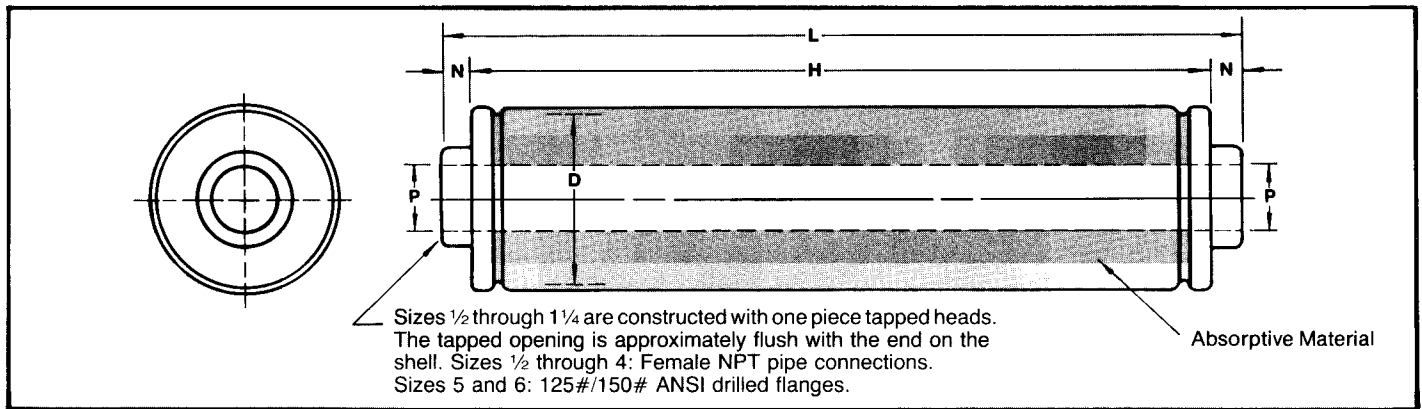

MODEL	P	D	L	N	H	WGT.
U5-1/2	1/2	3 1/4	8	—	8	2
U5-3/4	3/4	3 1/4	11	—	11	3
U5-1	1	3 1/4	14	—	14	3
U5-1 1/4	1 1/4	3 1/4	16	—	16	4
U5-1 1/2	1 1/2	4 1/4	19 3/4	1/2	18 7/8	6
U5-2	2	5 1/8	26	1/2	25	10
U5-2 1/2	2 1/2	6 1/8	33 1/2	1/2	32 1/2	15
U5-3	3	6 5/8	36 1/2	1/2	35 1/2	20
U5-4	4	8	48 7/8	1/8	48 3/4	40
U5-5	5	10	57	3	51	60
U5-6	6	12	63	3	57	100

Dimensions in Inches - Weight in Pounds

Specifications U2 Series

Straight-Through
Silencer

NOTE: U2 Series Standard Paint and Acoustical Packing are suitable for 325°F.

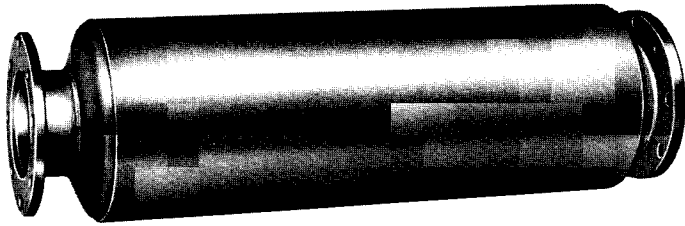
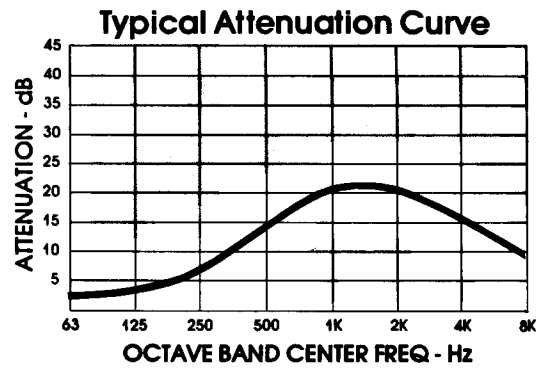

The U2 series is an economical straight-through silencer for applications not requiring higher-degree noise attenuation. It is fundamentally similar to the U5 series, however, attenuates less because of its relatively low length to diameter ratio. Mild steel construction, primer coated exterior.

Common Applications:

- Intermediate size Rotary Positive Blower inlet
- Inlet or discharge of Centrifugal Blowers
- Intermediate size dry Vacuum Pump discharge
- Gas Turbine inlet
- Inlet of high speed Centrifugal Compressor
- Any high frequency noise source

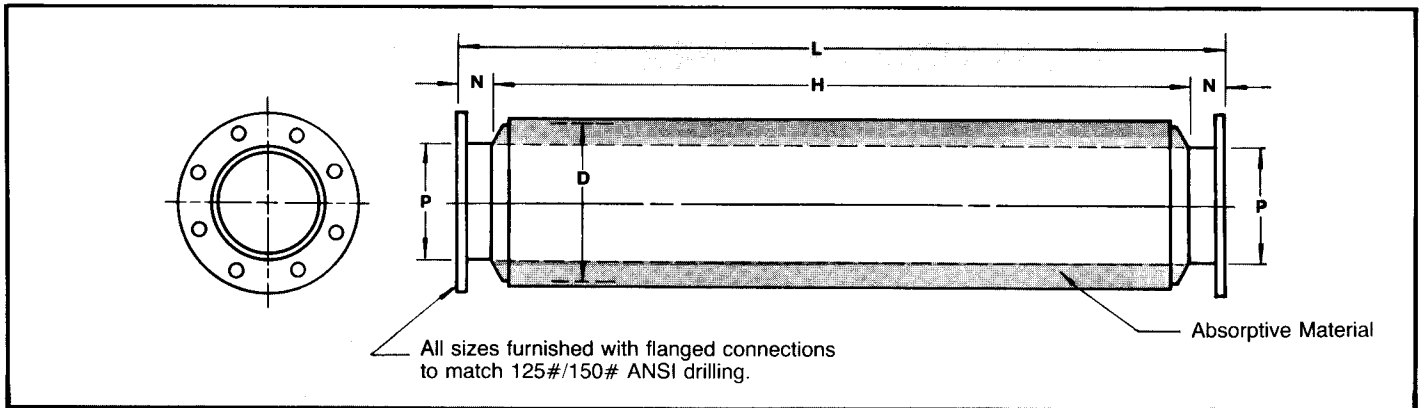

MODEL	P	D	L	N	H	WGT.
U2-5	5	10	36	3	30	45
U2-6	6	12	40	3	34	70
U2-8	8	14	53	3½	46	105
U2-10	10	16	65	3½	58	160
U2-12	12	18	77	3½	70	220
U2-14	14	20	89	3½	82	340
U2-16	16	22	101	3½	94	440
U2-18	18	24	113	3½	106	530
U2-20	20	26	128	4½	119	700
U2-22	22	28	140	4½	131	820
U2-24	24	30	152	4½	143	1,070
U2-30	30	36	189	4½	180	1,940

Dimensions in Inches - Weight in Pounds

Specifications SU5 Series

Annular Flow Silencer

NOTE: SU5 Series Standard Paint and Acoustical Packing are suitable for 325°F.

— 12" size and smaller
- - - 24" size and larger

Typical Attenuation Curve

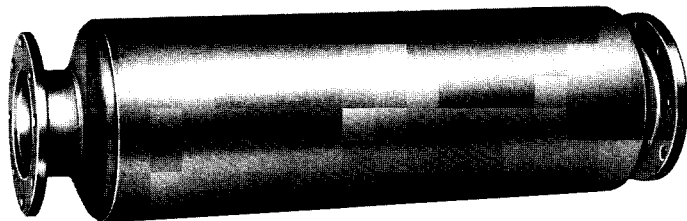
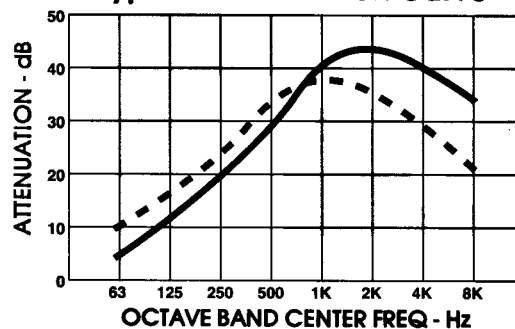

The SU5 series is our highest grade standard Absorptive silencer. Its design consists of two concentric perforated cylinders lined with acoustical pack, forming an annular flow path. This design features blocked-line-of-sight, while providing full flow area for low flow resistance. Mild steel construction, primer coated exterior.

Common Applications:

- Inlet and discharge of high speed, low pressure Centrifugal Compressors and Blowers (discharge P<15 psig)
- Inlet and discharge of Industrial Fans
- Inlet of high pressure Centrifugal Compressors
- Gas Turbine inlet
- Dry Vacuum Pump discharge
- Some low-pressure vents (<15 psig)
- Any high frequency noise source

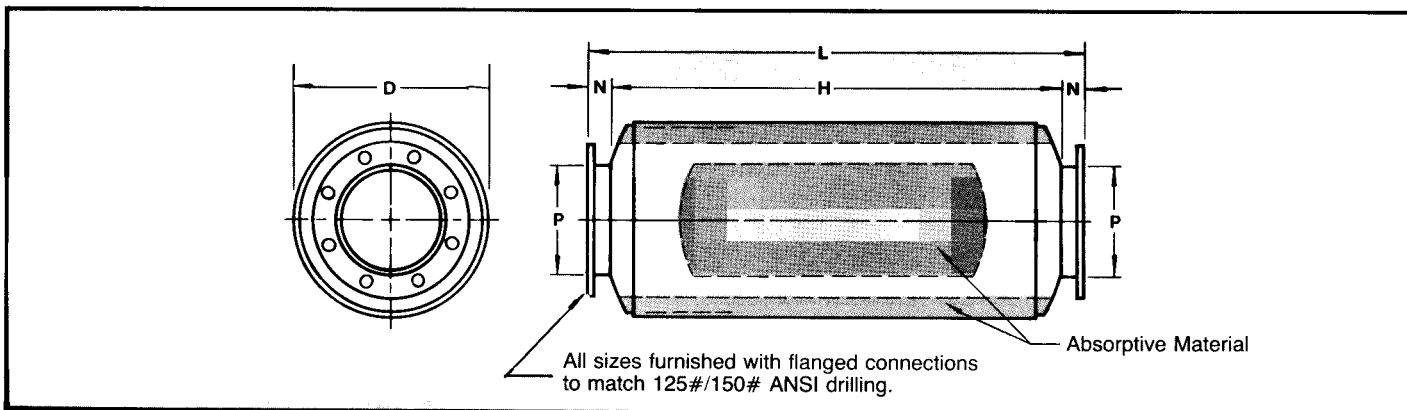

MODEL	P	D	L	N	H	WGT.
SU5-4	4	10	21½	3	15½	30
SU5-5	5	12	26	3	20	55
SU5-6	6	12	26	3	20	60
SU5-8	8	18	36	3½	29	120
SU5-10	10	20	44½	3½	37½	195
SU5-12	12	24	53	3½	46	290
SU5-14	14	26	61½	3½	54½	390
SU5-16	16	28	68	3½	61	500
SU5-18	18	30	74	3½	67	650
SU5-20	20	36	78	4½	69	950
SU5-22	22	36	89	4½	80	1,080
SU5-24	24	42	91	4½	82	1,400
SU5-26	26	42	102	4½	93	1,580
SU5-28	28	48	104	4½	95	2,200
SU5-30	30	48	115	4½	106	2,600
SU5-32	32	54	128	6	116	3,150
SU5-34	34	60	136	6	124	3,600
SU5-36	36	60	145	6	133	4,500
SU5-42	42	66	170	6	158	6,200
SU5-48	48	78	186	6	174	8,200
SU5-54	54	84	198	6	186	10,300
SU5-60	60	90	210	6	198	12,500

Dimensions in Inches - Weight in Pounds

Specifications SU4 Series

Annular Flow
Silencer

NOTE: SU4 Series Standard Paint and Acoustical Packing are suitable for 325°F.

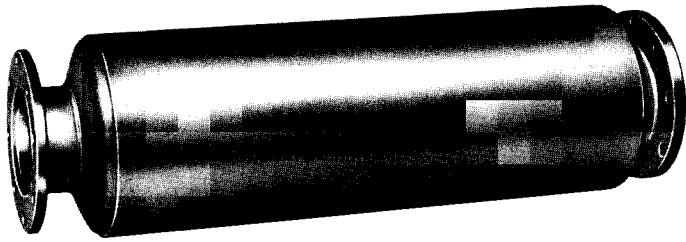
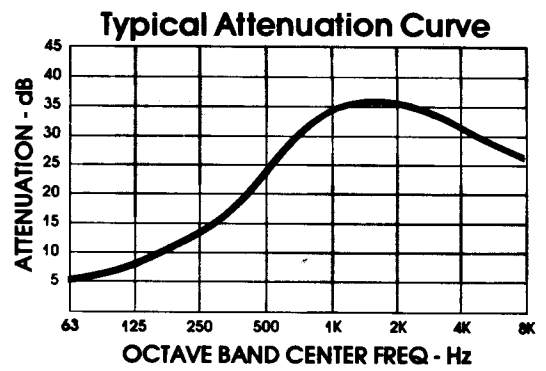

The SU4 series is Universal's second-highest grade Absorptive silencer, ranking just below the SU5 series. The design of this unit features a bullet centered in the flow tube to provide annular flow path and partial blocked-line-of-sight. Pressure drop is only slightly greater than the SU5. Mild steel construction, primer coated exterior.

Common Applications:

- Inlet of turbocharged Reciprocating Engine
- Inlet and discharge of high speed, low pressure Centrifugal Compressors and Blowers (discharge P<15 psig)
- Inlet and discharge of Industrial Fans
- Inlet of high pressure Centrifugal Compressors
- Gas Turbine inlet
- Dry Vacuum Pump discharge
- Some low-pressure vents (<15 psig)
- Any high frequency noise source

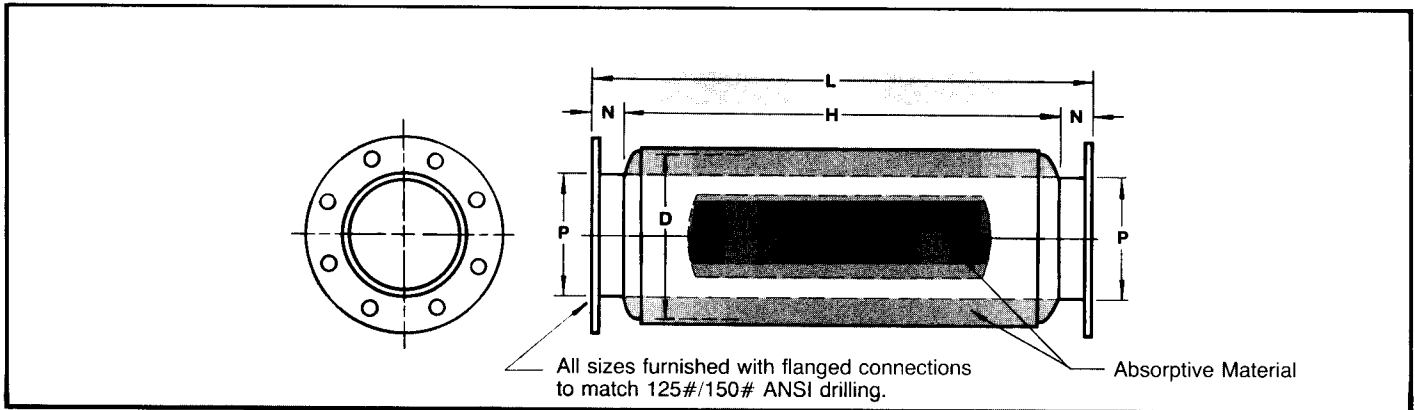

MODEL	P	D	L	N	H	WGT.
SU4-8	8	14	33	3½	26	90
SU4-10	10	16	35	3½	28	120
SU4-12	12	18	47	3½	40	180
SU4-14	14	20	51	3½	44	240
SU4-16	16	22	59	3½	52	320
SU4-18	18	24	63	3½	56	370
SU4-20	20	26	73½	4½	64½	490
SU4-22	22	28	73½	4½	64½	530
SU4-24	24	30	85½	4½	76½	720
SU4-30	30	36	108	4½	99	1,340
SU4-36	36	42	122	4½	113	2,020
SU4-42	42	48	137	6	125	3,200
SU4-48	48	54	161½	6	149½	4,100
SU4-54	54	60	178	6	166	5,400
SU4-60	60	66	192½	6	180½	7,300

Dimensions in Inches - Weight in Pounds

Specifications SU3 Series

Annular Flow
Silencer

NOTE: SU3 Series Standard Paint and Acoustical Packing are suitable for 325°F.

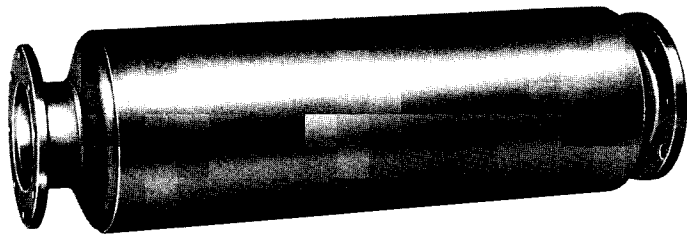
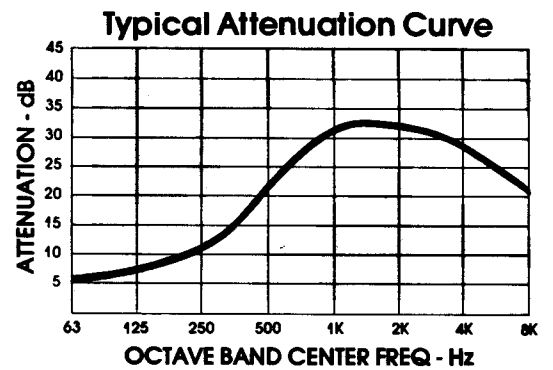

The SU3 series is the most economical of Universal's three grades of annular design silencers, ranking in performance below the SU5 and SU4 series. Its design - except for length - is almost identical to the SU4, including annular flow path and partial blocked-line-of-sight. Pressure drop coefficient is the same as for the SU4 series. Mild steel construction, primer coated exterior.

Common Applications:

- Inlet of turbocharged Reciprocating Engine
- Inlet and discharge of high speed, low pressure Centrifugal Compressors and Blowers (discharge P<15 psig)
- Inlet and discharge of Industrial Fans
- Inlet of high pressure Centrifugal Compressors
- Gas Turbine inlet
- Dry Vacuum Pump discharge
- Some low-pressure vents (<15 psig)
- Any high frequency noise source

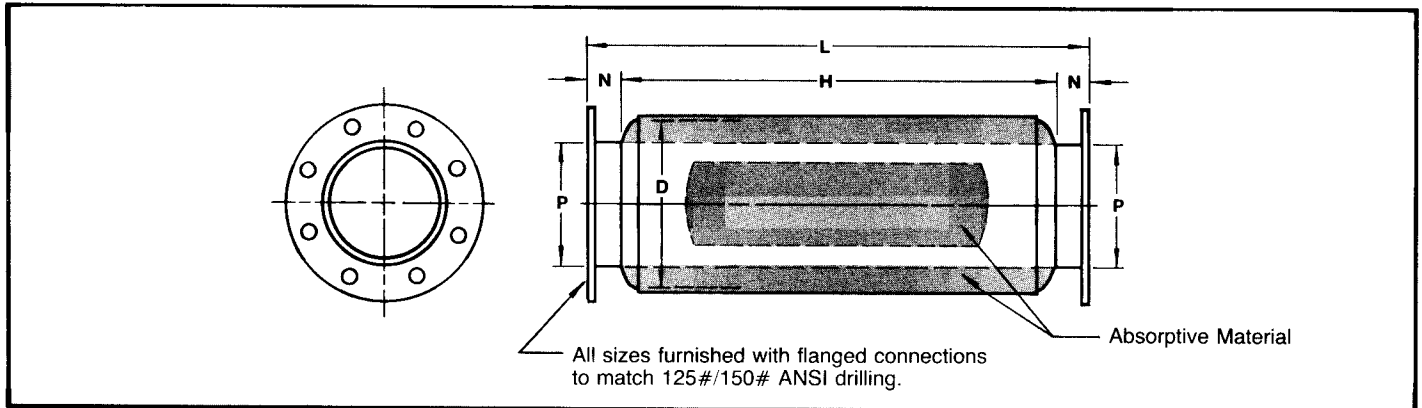

MODEL	P	D	L	N	H	WGT.
SU3-8	8	14	31	3½	24	85
SU3-10	10	16	35	3½	28	120
SU3-12	12	18	39	3½	32	155
SU3-14	14	20	39	3½	32	200
SU3-16	16	22	47	3½	40	270
SU3-18	18	24	47	3½	40	290
SU3-20	20	26	49½	4½	40½	350
SU3-22	22	28	55½	4½	46½	420
SU3-24	24	30	55½	4½	46½	500
SU3-26	26	30	61	4½	52	680
SU3-28	28	36	63½	4½	54½	830
SU3-30	30	36	62	4½	53	890
SU3-32	32	36	68	4½	59	1,120
SU3-34	34	42	75	4½	66	1,360
SU3-36	36	42	80	4½	71	1,490
SU3-42	42	48	83	6	71	1,920
SU3-48	48	54	89½	6	77½	2,600
SU3-54	54	60	96	6	84	3,300
SU3-60	60	66	108½	6	96½	4,430

Dimensions in Inches - Weight in Pounds

Absorptive Silencers

**CONTACT UNIVERSAL SILENCER FOR ALL YOUR
INDUSTRIAL SILENCING AND AIR FILTERING
REQUIREMENTS.**

**Complete Lines of Silencers and Air Filters/Filter-
Silencers for**

- Rotary Positive Blowers and Vacuum Pumps
- Reciprocating Engines
- Gas Turbine Engines
- High Pressure Vents & Blowdowns
- Centrifugal Compressors
- Specialty Applications (Such as Pressure Reduction
Valves, Rotary Screw Compressors, etc.)

Representatives in Major Industrial Areas of U.S.
and Canada

Write for Literature

Represented By:



UNIVERSAL SILENCER

A DIVISION OF NELSON INDUSTRIES, INC.
P.O. Box 411, Stoughton, Wisconsin 53589
608-873-4272 Fax 608-873-4298