

Acousti-Vane™ Silencers

- Excellent for gas turbine inlets, axial fans, and compressors
- Modular, compact, and lightweight
- Low-cost, corrosion-resistant materials
- Superb low-frequency insertion loss
- Suited for a wide range of applications and temperatures

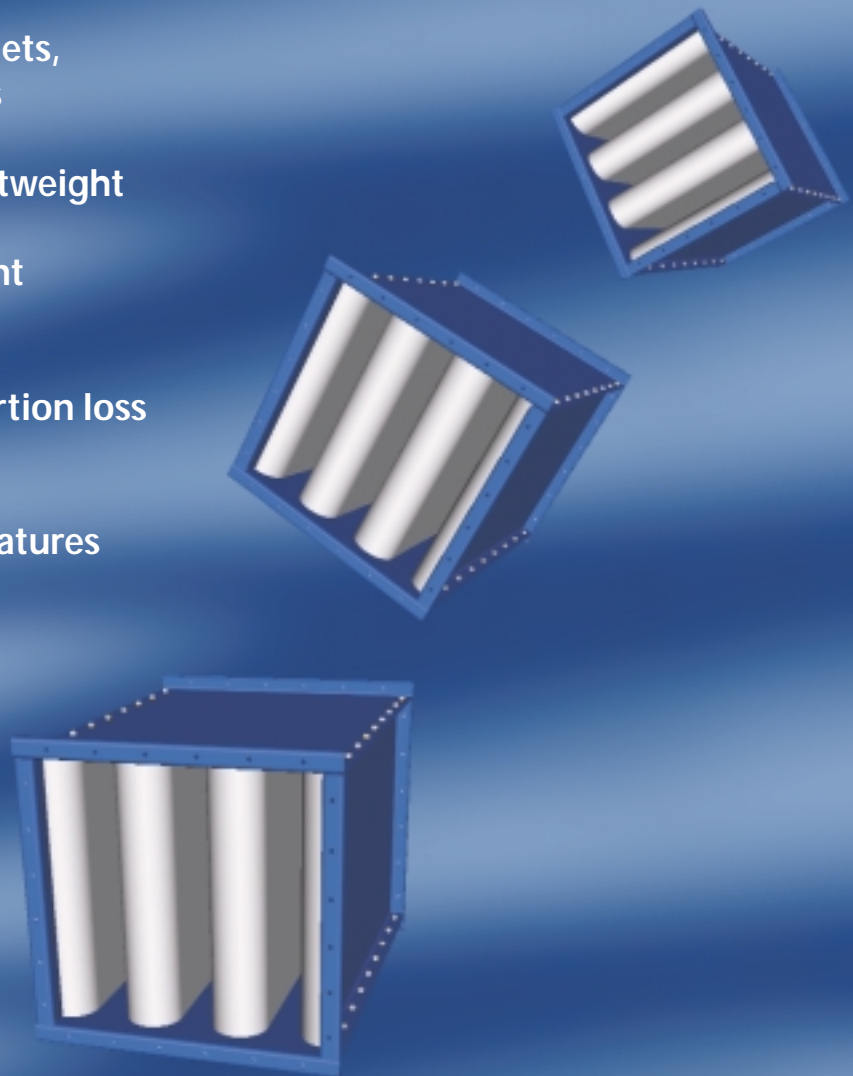

UNIVERSAL SILENCER

A FLEETGUARD/NELSON COMPANY

Noise Control and Air Filtration

UNIVERSAL SILENCER ACOUSTI-VANE SILENCER SERIES

The Acousti-Vane silencer is designed to be used as a standalone silencer or in series with Universal Silencer's Acousti-Tube® silencer. The superior noise attenuation of the Acousti-Vane, combined with the superior high-frequency performance of the Acousti-Tube, will provide excellent noise control over a broad spectrum.

Quietly conditioning noise

The Acousti-Vane silencer comes in standard cross-sections and lengths that cover a wide range of applications and provide economical solutions to a broad range of noise conditions. Standard units can be adapted for use in non-standard or application-specific configurations.

The Acousti-Vane comes in three standard models:

- **LP** — The low-pressure-drop Acousti-Vane has lower pressure drop than the other two models and is the most economical of the three. The LP is the silencer of choice when pressure drop is critical and a relatively small amount of noise attenuation is needed.
- **MP** — The moderate-pressure-drop Acousti-Vane offers greater acoustic performance than the LP at a slightly higher pressure drop. The MP model meets most noise attenuation specifications.
- **HP** — The high-performance Acousti-Vane provides maximum acoustic performance at a higher pressure drop than the LP or MP. The HP model is ideal for the most demanding acoustical environment.

The steel frame for Acousti-Vane silencers has high sound transmission loss. The standard shell finish includes solvent-cleaning by SSPC-SP-1, shop coat primer inside and outside, and a blue enamel coating outside. The paint system withstands internal gas temperatures and skin temperatures up to 200° F. Optional paint systems are available.

Specifying performance is easy

Only three parameters are needed to select the correct silencer: required acoustic insertion loss, allowable pressure loss, and the flow in actual cubic feet per minute (acfm) for your equipment.

The tables on the facing page have been set up to allow selection of the appropriate Acousti-Vane silencer using these three parameters.

Follow these steps to find the silencer that is most appropriate for your application:

- 1** Determine the required dynamic insertion loss by octave band for your equipment.
- 2** For each of the three models in Table 1 (LP, MP, and HP), select the minimum silencer length that gives the required octave band insertion loss.
- 3** Determine the allowable pressure drop (inches of H₂O) and flow in acfm for your application.

To find the pressure drop for gas temperatures other than 60° F, multiply the selected value by $[520/(\text{actual gas temperature } ^\circ\text{F} + 460)]$.

- 4** Choose the Acousti-Vane model for your application. From the three graphs in Table 1, choose the one that has the allowable pressure drop on the y-axis. Read straight across until the line meets the pressure drop curve.

The corresponding x-axis value is the maximum face velocity that will maintain the pressure drop requirement.

- 5** Divide the acfm by the required face velocity to find the minimum silencer cross-section that would give the required pressure drop.

Face velocity is defined as the flow rate in acfm divided by the silencer face area in square feet (see Table 2).

608.873.4272

Internet E-mail: US@universal-silencer.com
On the Web: www.universal-silencer.com

TABLE 1. Dynamic insertion loss in dB for face velocities <1500 fpm, and pressure drop for gas temperatures of 60° F.
 To find the pressure drop for gas temperatures other than 60° F, multiply the selected value by
 $[520/(\text{actual gas temperature } ^\circ\text{F} + 460)]$. Contact Universal Silencer for information about face velocities >2000 fpm.

LP (low pressure drop) Model

Silencer Length (ft)	Octave Bands (Hz)								
	31.5	63	125	250	500	1 k	2 k	4 k	8 k
3	1	2	4	5	7	5	3	2	1
4	1	3	5	9	9	8	4	4	2
5	2	4	6	10	11	10	7	5	2
6	2	4	7	13	13	12	9	6	4
7	2	5	8	15	15	12	11	7	5
8	3	5	8	16	18	14	13	9	7
9	3	6	9	18	21	16	15	11	9
10	3	6	10	20	24	20	18	14	11
11	4	7	11	22	26	20	18	14	11
12	4	7	12	24	28	20	18	14	11

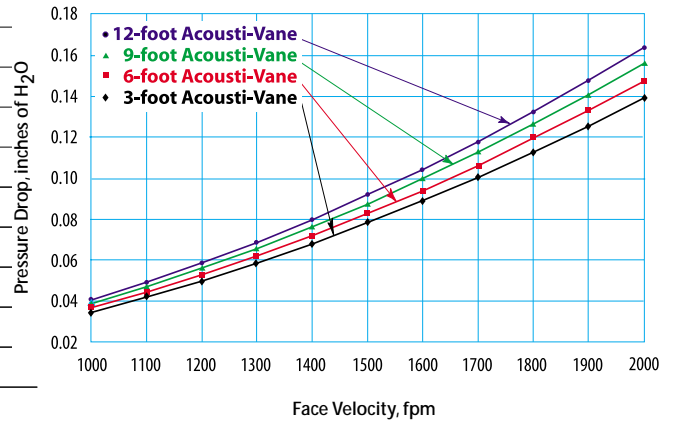

MP (moderate pressure drop) Model

Silencer Length (ft)	Octave Bands (Hz)								
	31.5	63	125	250	500	1 k	2 k	4 k	8 k
3	3	4	7	10	12	13	11	9	5
4	3	4	8	12	16	16	13	11	7
5	3	5	9	15	20	20	15	12	8
6	3	5	9	18	25	22	18	13	9
7	4	6	10	20	27	24	21	14	9
8	4	6	10	22	29	27	24	15	10
9	5	7	12	24	30	29	26	16	12
10	5	7	14	25	32	32	28	18	14
11	6	8	15	26	34	32	28	18	14
12	6	8	15	28	36	32	28	18	14

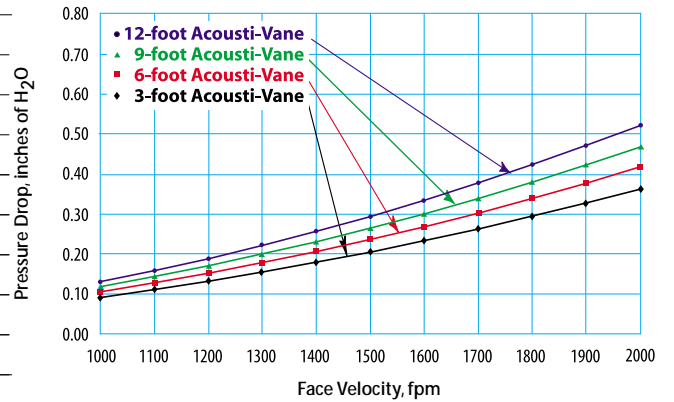

HP (high performance) Model

Silencer Length (ft)	Octave Bands (Hz)								
	31.5	63	125	250	500	1 k	2 k	4 k	8 k
3	3	5	9	13	15	16	16	12	7
4	3	6	10	16	18	20	20	14	10
5	4	7	12	21	22	23	24	16	12
6	4	8	14	23	26	27	27	19	14
7	5	8	15	25	30	31	31	21	16
8	5	9	16	27	33	36	33	24	18
9	5	9	17	29	36	41	36	27	20
10	6	10	19	31	39	46	39	30	22
11	6	10	19	33	42	47	42	30	23
12	7	11	20	35	45	48	45	30	24

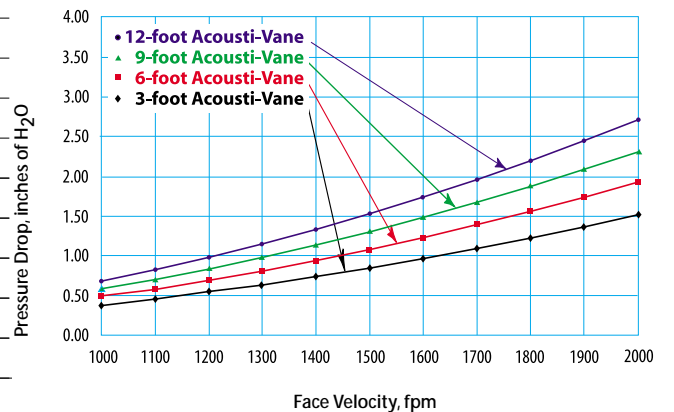
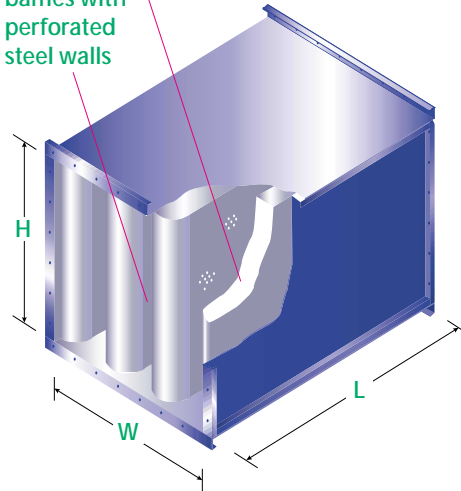

TABLE 2. Acousti-Vane part numbers and face areas.

Part No. (AV-H x W-L-__P)	Face Area (sq ft)
AV-2 x 2-L-__P	4.00
AV-2 x 3-L-__P	6.00
AV-2 x 4-L-__P	8.00
AV-3 x 4-L-__P	12.00
AV-4 x 4-L-__P	16.00
AV-4 x 6-L-__P	24.00
AV-5 x 6-L-__P	30.00
AV-6 x 6-L-__P	36.00
AV-6 x 8-L-__P	48.00
AV-7.5 x 7.5-L-__P	56.25
AV-8 x 8-L-__P	64.00

absorptive pack material

baffles with perforated steel walls



- 6** Select the silencer from Table 2. Replace *L* in the part number with the length of silencer you found in step 2. Specify whether the silencer is an LP, MP, or HP model. The pressure drop will be equal to or slightly below the allowable pressure drop you selected. For special applications that require minimum pressure drop and demanding acoustic specifications, contact Universal Silencer.

FIGURE 1. Guide to Acousti-Vane dimensions.

The silencer comes in standard cross-sectional dimensions and standard flange patterns. Flange patterns also can be designed to match your specifications. Silencers may be applied at temperatures that range between -20° F and 200° F. For standard flange patterns, silencer weights, and other details, see Technical Bulletin 94-1327.

Example case: Acousti-Vane Selection for a Gas Turbine Inlet

- The insertion loss needed to attenuate noise is determined to be 4, 7, 12, 20, 20, 18, 18, 14, 11 in the octave band center frequencies 31.5 Hz - 8 kHz.
- Table 1 shows that a 12-ft LP, 9-ft MP, or a 5-ft HP would satisfy the requirements.
- For this application the allowable pressure drop is 0.25 inches of water. Maintaining 0.25 inches of water pressure drop eliminates the HP model. For purposes of example, the flow in acfm is assumed to be 30,000.
- The graphs in Table 1 show that the maximum face velocity to achieve 0.25 inches of water is 2,000 fpm for the 12-ft LP and 1,500 fpm for the 9-ft MP.
- Divide the flow in acfm by the required face velocity for each silencer:

$$LP = 30,000/2,000 = 15 \text{ ft}^2$$

$$MP = 30,000/1,500 = 20 \text{ ft}^2$$
- These two silencers meet your specifications. Choose the one that best fits your application:
 - AV-4x4-12-LP
 - or
 - AV-4x6-9-MP

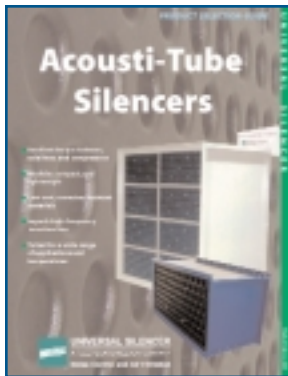

Acousti-Tube for high-frequency applications

More information about the Universal Silencer Acousti-Tube gas turbine inlet silencer for high-frequency attenuation may be found in product catalog 260 and technical bulletin 94-1315.



On the Internet . . .

E-mail:

US@universal-silencer.com

On the Web:

www.universal-silencer.com

Acousti-Vane Silencers



Our corporate headquarters are located in Stoughton, Wisconsin, just southeast of Madison, the state capital. This new building houses administration, sales, and engineering departments.

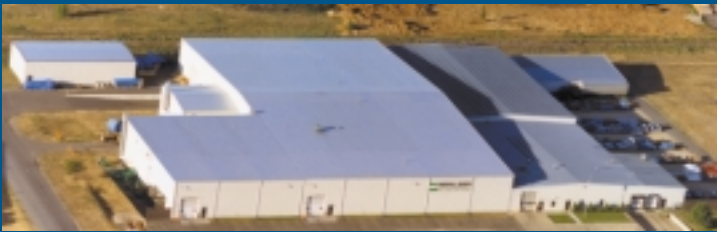

Manufacturing facilities are in Muscodia (above), 75 miles west of Stoughton, and Montello (below), 70 miles north.



Our products have been used to protect, quiet, and optimize the performance of industrial equipment for 40 years. We maintain a fully equipped testing facility to qualify filters and silencers. We are an ISO 9001 registered firm and ASME Code certified.

Keeping industrial equipment clean and quiet.



Contact us for more information about our complete line of industrial silencers, air filters, and filter-silencers:

- Universal Silencer guide to gas turbine products, catalog 265
- Gas turbine products, catalog B-249-A
- Acousti-Vane™ silencers, technical bulletin 94-1327
- Acousti-Tube® silencers, catalog 260
- Acousti-Tube® silencers, technical bulletin 94-1315
- StrataClean™ barrier air filter systems, catalog 268
- StrataClean™ Pulse air filter systems, catalog 269
- Air filters and filter-silencers, catalog 241-A
- Cartridge air filters and filter-silencers, catalog 242-C
- CB compact blower silencers, catalog 255-A
- CBF/CBFI compact blower filter-silencers, catalog 261-A
- Air filter restriction gauge, catalog 81-1234
- Reciprocating engine silencers, catalog 246-A
- Rotary positive blower silencers, catalog 244-D
- Absorptive silencers, catalog 245-B
- Vent and blowdown silencers, catalog 243-C
- Compressor silencers, information provided by application
- Vacuum pump separator silencers, catalog 222-B
- Industrial fan silencers, catalog 249-A, 249-D
- Silencers for steam ejectors, pressure reduction valves, and other special applications

UNIVERSAL SILENCER

A FLEETGUARD/NELSON COMPANY
 P. O. Box 411, Stoughton, Wisconsin 53589
 608-873-4272 Fax 608-873-4298

Internet E-mail: US@universal-silencer.com
 On the Web: www.universal-silencer.com