

# AIR FILTRATION PRODUCTS

## Air Filter Restriction Gauge 81-1234

For cartridge and panel filter housings  
CBF, CBFI, CCF, CF, CCS, CS, FH, FSH, FRH, FCRH, FASH, FMH,  
ILF, ILFS, RF, RFY, RFS, RFSY

### Saves energy, labor, material

- Accurate monitoring ensures that filter elements are replaced and serviced only when necessary.

### Easy to check filter life

- Convenient monitoring saves maintenance time.
- The gauge is easy to read, even at a distance.

**U**niversal's air filter restriction gauge provides a convenient, inexpensive means of monitoring filter element restriction and remaining life of the filter element.

The yellow indicator in the filter restriction gauge drops progressively as the filter element is loaded with dirt. When the indicator reaches the mark recommended by the equipment manufacturer, it's time to change or service the filter.

The gauge measures up to 20 inches of water and allows you to determine the condition of the filter element even after the equipment is shut down. After the element has been replaced, just push the reset button on the top of the gauge to reset it to the original clean-filter position.

The manufacturer of the equipment in which the filter is installed can recommend the maximum pressure drop at which the filter should be serviced. The maximum restriction recommended across Universal Silencer's filter elements is 20 inches of water, but this value may be greater than the equipment can tolerate for best efficiency. Thus, the filter element should be serviced or replaced at either the manufacturer's recommendation or 20 inches of water, whichever is smaller.

The restriction gauge is equipped with a 1/8" male NPT and may be threaded directly into a 1/8" female NPT fitting.

If the gauge is to be installed in a 1/4" female fitting, a 1/4" x 1/8" NPT adapter is required.

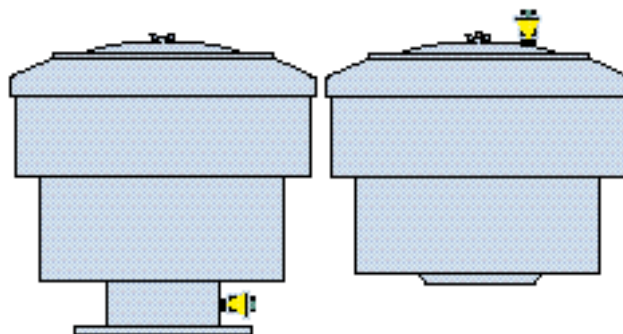

NOZZLE MOUNT

WEATHERHOOD MOUNT

Mount the gauge in the nozzle with a 1/4" x 1/8" NPT adapter, as shown at left, or mount it on the weatherhood in the 1/8" FNPT opening, as shown on the right.

Order part number 81-1234.

**608.873.4272**

Internet E-mail: [US@universal-silencer.com](mailto:US@universal-silencer.com)

On the Web: [www.universal-silencer.com](http://www.universal-silencer.com)



**UNIVERSAL SILENCER**

**A FLEETGUARD/NELSON COMPANY**

**Noise Control and Air Filtration**



Our corporate headquarters are located in Stoughton, Wisconsin, just southeast of Madison, the state capital. This new building houses administration, sales, and engineering departments. Manufacturing facilities are in Muscoda, 75 miles west of Stoughton, and Montello, 70 miles north.



Our products have been used to protect, quiet, and optimize the performance of industrial equipment for almost 40 years. We maintain a fully equipped facility for testing filters and silencers under actual operating conditions. We are an ISO 9001 registered firm and ASME Code certified.

*Keeping industrial equipment clean and quiet.*



# AIR FILTRATION

## Filter Gauge 81-1234

The yellow indicator in the filter restriction gauge drops progressively as the filter element is loaded with dirt. When the indicator reaches the mark recommended by the equipment manufacturer, it's time to change or service the filter, as shown in the example below.

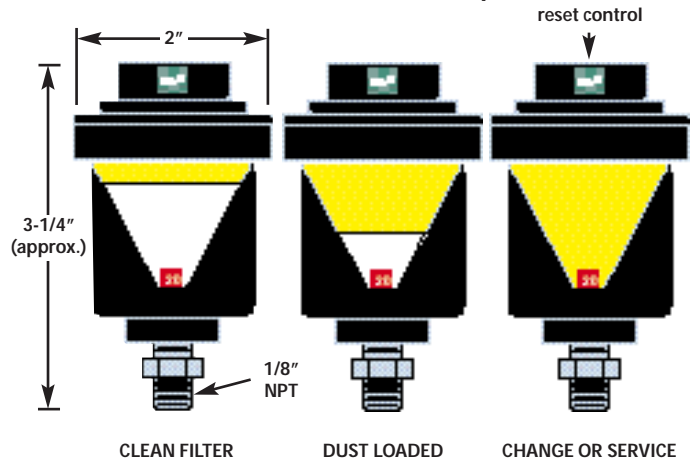

Contact us for more information about our complete line of industrial silencers and air filter/filter silencers:

- Air filters and filter silencers, catalog 241-A
- Cartridge air filters and filter silencers, catalog 242-B
- CB compact blower silencers, catalog 255-A
- CBF/CBFI compact blower filter-silencers, catalog 261-A
- Vent silencers, catalog 243-B
- Vent silencer specification sheet, form 88-0063
- Reciprocating engines, catalog 246-A
- Rotary positive blowers, catalog 244-D
- Axial fans, catalog 249-D
- Compressors, information provided by application
- Vacuum pumps, catalog 222-B
- Industrial fans, catalog 249-A
- Steam ejectors, pressure reduction valves, and other special applications

## UNIVERSAL SILENCER

A FLEETGUARD/NELSON COMPANY  
 P. O. Box 411, Stoughton, Wisconsin 53589  
 608-473-4272 Fax 608-473-4288

Internet E-mail: [US@universal-silencer.com](mailto:US@universal-silencer.com)  
 On the Web: [www.universal-silencer.com](http://www.universal-silencer.com)